

Mizuno, T. and Y. Toriyabe. *Anomalous energy generation during conventional electrolysis*. in *The 12th International Conference on Condensed Matter Nuclear Science*. 2005. Yokohama, Japan.

This Acrobat file also includes the PowerPoint slides from the conference presentation of this paper.

Anomalous energy generation during conventional electrolysis

Tadahiko Mizuno and Yu Toriyabe: Department of Engineering, Hokkaido University

We experienced an explosive energy release during a conventional electrolysis experiment. The cell was a 1000 cc Pyrex glass vessel that has been in use for 5 years. It contained 700 cc of 0.2 M K_2CO_3 electrolyte; a platinum mesh anode; and a tungsten cathode wire 1.5 mm in diameter, 29 cm long, with 3 cm exposed to the electrolyte. The estimated heat out was 800 times higher than input power, based on the data recorded up to the moment of the event. There were many elements deposited on the electrode surface. The major elements were Ca and S and the total mol was roughly estimated as 10^{-6} .

1. Introduction

We have performed hundreds of test runs of the plasma glow discharge, including many that produced excess heat. On January 24, 2005, a plasma cell exploded, producing far more energy than input power can account for. This event, as well as normal excess heat runs, is described below.

2. Experiment

2.1 Electrolysis cell

Figure 1 shows the experimental set up, which is described in Ref. 1 and 2. We measure many parameters including sample surface temperature, neutron and x-ray emission, mass spectrum of gas, input and output power, and so on. Figure 2 shows the schematic sketch of the cell and gas measurement system^(1,2). The cell is made of Pyrex glass. It is 10 cm diameter and 17 cm in height and 1000 cc in solution capacity. It is closed with a Teflon rubber cap, 7 cm in diameter. The cap has several holes in it, three for platinum resistance temperature detectors (RTD) (Netsushin Co., Plamic Pt-100 Ω), two for the inlet and outlet of the flowing coolant water, and one to hold a funnel that captures the effluent gas from the cathode. The funnel is made of quartz glass, and is 5 cm in the diameter at the top of the cell, and 12 cm in length. Gas leaving from the top of the funnel flows into a water-cooled condenser, which is connected to the funnel with another Teflon rubber cap.

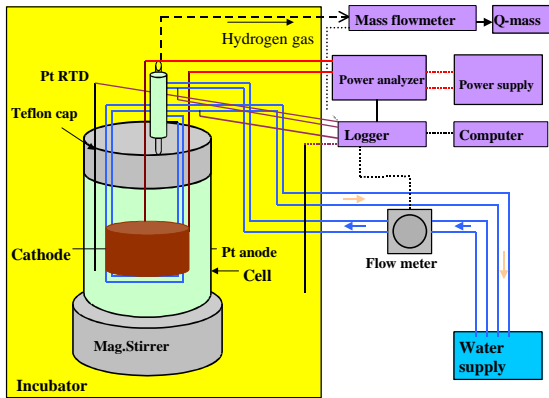

Fig. 1. Experimental set up

We measured several parameters, including the rate of gas flow, temperature of the sample surface, mass spectrum of gas and input power. The measurement system was described elsewhere ^(1,2). The electrolyte was composed by basic K_2CO_3 solution and the volume was 700 cc. Plasma discharge was change by input voltage up to 350 V. The gas generated by the plasma discharge was continuously analyzed by the quadrupole mass spectrometer.

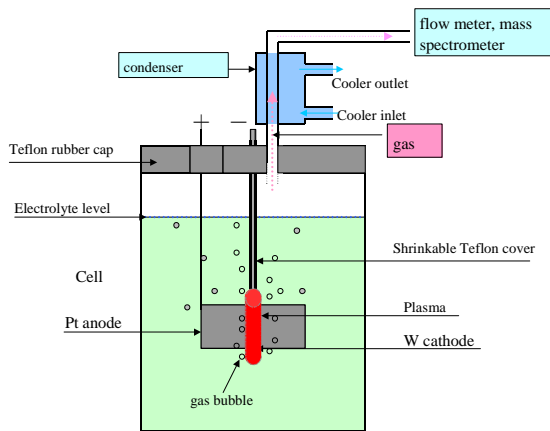

Fig.2. Detail of gas measurement

2.2 Measurement of hydrogen gas

A mixture of steam, hydrogen and oxygen (from pyrolysis) passes from the cell to the condenser. The steam condenses and falls back into the cell. An 8-mm diameter Tigon tube is coupled with the gas exit of the condenser, connecting it to a gas flow meter (Kofloc Co., model 3100; controller: Kofloc Co., model CR-700).

The gas flowmeter is a heated tube of thermal flow meter system, the minimum detection rate of hydrogen gas flow is 0.001 cc/s, and the resolution is within 1%.

After the gas passes through the flow meter, a small constant volume of gas, approximately 0.001 cc/s, passes through a needle valve and is analyzed by the quadrupole mass spectrometer. The rest of the gas is vented. The main composition of gas released from the cathode was then continuously analyzed by the mass spectrometer.

2.3 Calorimetry

Temperature measurements were made with 1.5 mm diameter RTDs. Calorimetry was performed by combining the flow and isoperibolic method. Flow calorimetry is based on the temperature change of the cooling water. The cooling water is tap water flowing through Tigon tubing. It passes first through a constant temperature bath to keep the temperature constant. From there, it flows through the outer jacket of the condenser, and then through the coil of tubing wrapped around the funnel. (The outside of this cooling water coil is covered with the anode, a platinum mesh). The flow rate is measured with a turbine meter (Japan Flow Control Ltd., model T-1965B). The inlet temperature is measured before the cooling water enters the condenser, and outlet temperature is measured where it exits the cell. Heat from both condensation and glow discharge electrolysis are combined together.

Isoperibolic calorimetry is performed by placing three other RTDs in the cell electrolyte at different depths in the solution to measure the temperature. The solution is mixed with a magnetic stirrer.

Figure 3 shows a notional sketch of the heat measurement system. Heat out can be divided into several factors. These are energy for water decomposition, heat of electrolyte, heat bring by the coolant, heat releasing from the cell wall and heat releasing with the vapor through the cell plug.

The heat balance is estimated by input and output formulas, input and output power is given in the following equations:

$$\cdot \text{Input (J)} = \mathbf{I} \text{ (current)} \cdot \mathbf{V} \text{ (Volt)} \cdot \mathbf{t},$$

$$\cdot \text{Out} = H_g + H_w + H_c + H_r,$$

here,

$$H_g = \text{Heat of decomposition} = \int 1.48 \cdot dI \cdot dt$$

$$H_w = \text{Electrolyte heat} = \int W_w \cdot C_w \cdot \delta T; \quad W_w: \text{electrolyte weight}, C_w: \text{heat capacity}, \\ \delta T: \text{temperature difference}$$

$$H_c = \text{Heat of coolant} = \int W_c \cdot C_c \cdot \delta T; \quad W_c: \text{coolant weight}, C_c: \text{heat capacity}, \\ \delta T: \text{temperature difference}$$

$$H_r = \text{Heat release} = \int (W_w \cdot C_w + W_c \cdot C_c) Tr; \quad Tr: \text{temperature change}$$

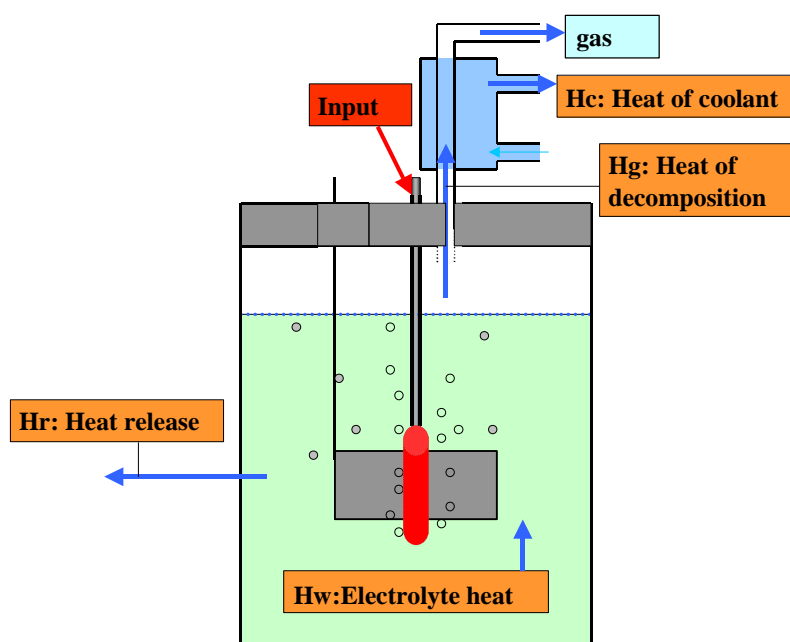

Fig. 3. Schematic representation of heat balance

Input power is only from the electric power source. Output is divided into several parts. The first factor is heat of water decomposition (designated Hg). It is easily calculated from the total electric current. The second factor is electrolyte enthalpy (Hw). It is easily derived from the solution temperature difference. The third factor is heat removed by the coolant (Hc). This is measured from the temperature difference between the coolant inlet and outlet, and the coolant flow rate. The fourth factor is heat release from the cell (Hr). This is rather complicated and can be estimated with a semi-empirical equation. We measured most of the heat in the condenser directly by monitoring the inlet and outlet temperature of the cooling water that passes through the condenser outer jacket.

If there is a mixture of various gases, we have to measure the gas composition precisely, because even a small volume of gas generated by pyrolysis will remove a large amount of enthalpy. This was done with the precision gas flow meter and mass analysis. The first factor, water decomposition (Hg) has a large effect on the rest of the equation.

2.4 Electrode and solution

The electrode is tungsten wire, 1.5 mm in diameter and 15 cm in length. The upper 13 cm of the wire is covered with shrink-wrap Teflon and the bottom 2 cm is exposed to the electrolyte and acts as an electrode. During electrolysis, the sample wire was consumed. The electrolyte solution was made from high purity K_2CO_3 reagent at 0.2 M concentration.

2.5 Power supply

The power supply was a model of EH1500H made by Takasago Co. Ltd.. The electric power was collected with a power meter (Yokogawa Co., model PZ4000) in every 5 seconds. The electric power was measured in each 40 μ s, and the average of 100,000 values was recorded at 5-second intervals.

2.6 Data collection

All data, including the mass of cooling water flow from the flow calorimetry, the temperature of coolant entrance and exit, electrolyte temperature measured by three RTDs, input voltage, current, electric power and the amount of the hydrogen gas generated were collected by a data logger (Agilent Co., model 34970A), and stored in a personal computer.

2.7 Element analysis

The sample electrodes and the electrolyte were subjected to element analysis by means of energy dispersion X-ray spectroscopy (EDX), Auger electron spectroscopy (AES), secondary ion mass spectroscopy (SIMS) and electron probe micro analyzer (EPMA).

2.8 Mass analysis

The generated gas was continuously analyzed a quadrupole mass spectrometer (Ulvac Rega-201). A small amount of gas was introduced into a differential evacuation system and then brought to the mass spectrometer. The analyzer can measure mass number from 2 to 400.

3. Results and Discussion

4.2 Normal experiment

Figure 4 shows changes of input voltage, cell temperature and current for a typical normal experiment. Input voltage is increased in steps from 0 V to more than 100 V and then decreased to 0 V. The input current usually rises to a maximum value of 4.3 A during conventional electrolysis with 1 cm² area of W electrode, but it usually decreases once plasma forms, and stays around 1.6 A, while voltage ranges from 120 V to 220 V.

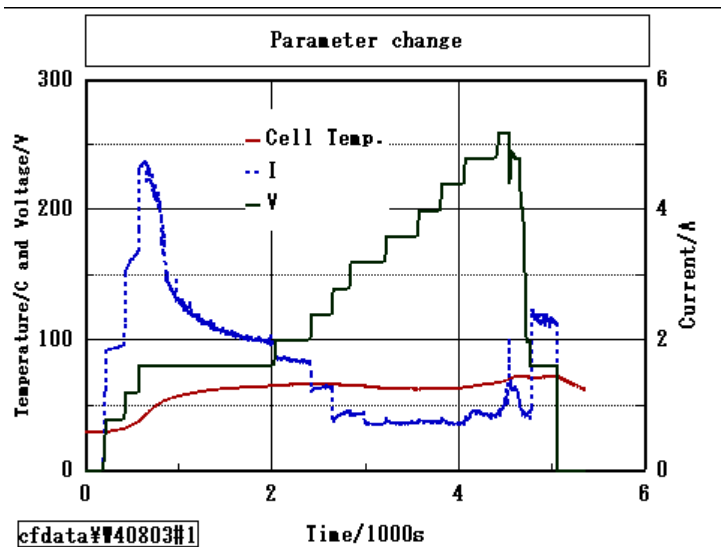

Fig. 4. Changes of voltage, cell temperature and current

The time-expanded graph of Fig. 4 is shown in Fig. 5. It indicates input voltage, current and temperature changes for the first 250 s in the Fig. 4. Here, input voltage was increased at 182 s and it reached to 40V at 220 s, and at the same time, current increased to 1.8 A. Meanwhile, the electrolyte temperature rose only 1°C, which is to say it was almost constant.

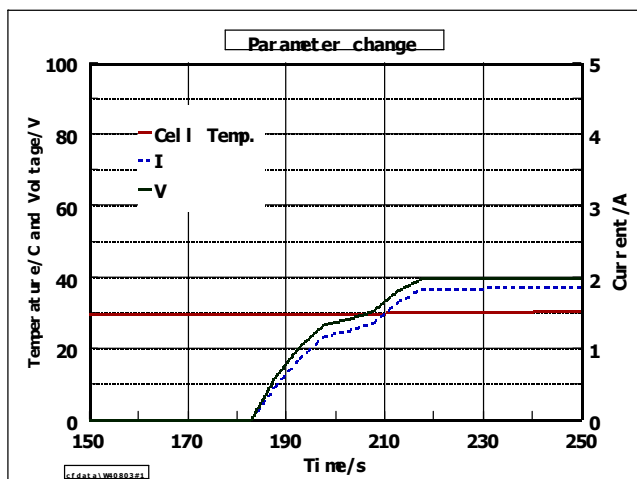

Fig. 5. Time expanded graph of Fig. 4

3.2 Explosion

The changes of temperature during the explosive reaction were different from the usual experiment.

The cell was placed inside a constant temperature air-cooled incubator (Yamato 1L-6) with the outer door open, and the inner Plexiglas safety door closed. The event occurred in the first stage of the experiment before plasma normally forms. The input voltage and current were 15 V and 1.5 A at 40 s, or 22.5 W, as shown in Fig. 6. Input power was supplied for 10 s, so total input was roughly 300 J. Within 10 seconds after turning on the power, the cell temperature began rising steeply. It rose to 80°C and a bright white flash surrounded the cathode. The light expanded to the solution and at the same instant the cell was shattered by the sharp increase of inner pressure. The explosion blew off the Plexiglas safety door and spread shards of Pyrex glass and electrolyte up to 5 ~ 6 m into the surrounding area.

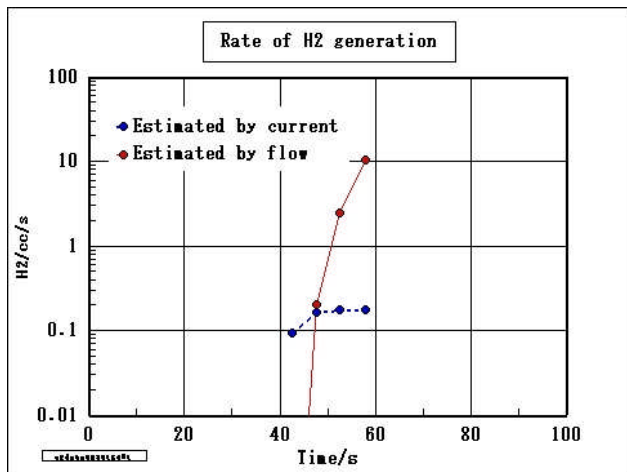

Fig. 6. Changes in hydrogen generation and temperature at the time of the explosion.

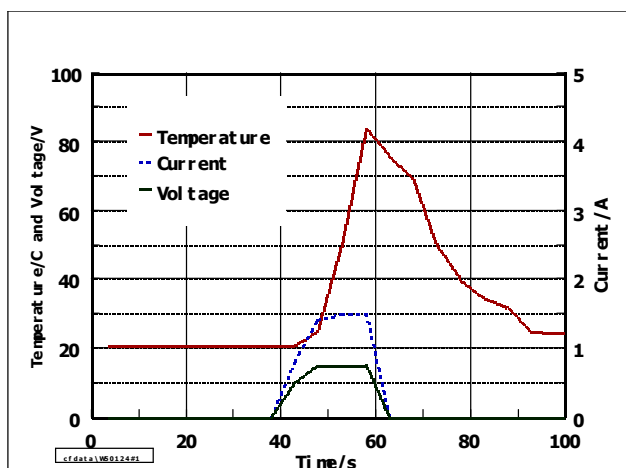

Fig. 7. Changes of voltage, cell temperature and current at the time of the explosion

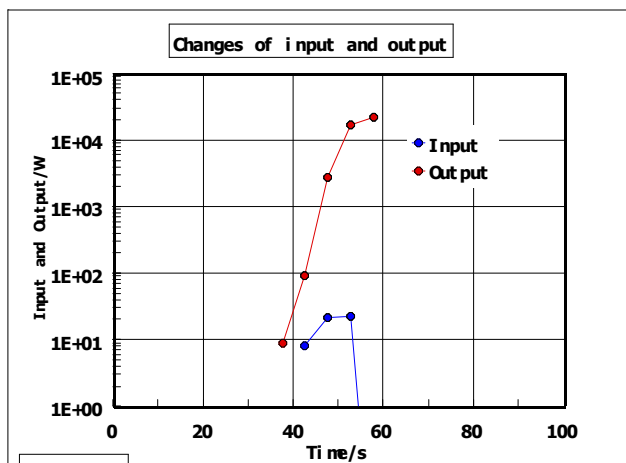

Fig. 8. Changes in input and output heat at the time of the explosion.

The flow of hydrogen gas from the cell (Fig. 6) increased just before the explosion, to levels higher than the current could have produced from electrolysis. This extra hydrogen came from pyrolysis caused by the intense heat.

The magnetic stirrer ensures that the fluid is well mixed with a uniform temperature. The three separate RTDs in the electrolyte all recorded between 70 and 80°C just before the explosion. The last four data points collected before the explosion (Table 1) show that the fluid temperature was rising rapidly and that the temperature was uniform, which proves the fluid was well mixed. A thermal gradient appeared in the last few seconds, but the entire 700 ml volume of water was heated from 25°C to at least 70°C. This takes 31,500 calories or 132,000 J (441 times the input energy). To this we must add the enthalpy carried off by the hydrogen from electrolysis and pyrolysis, which does not raise the electrolyte temperature. Finally, additional energy must have been generated in the seconds before the explosion after the last data point was recorded. Taking into account these factors, we estimate the reaction produced ~800 times more energy than was input into the cell prior to the explosion.

Table 1. Last four RTD electrolyte temperature readings prior to explosion

RTD	Location below electrolyte surface	Seconds before explosion			
		20 seconds	15 seconds	10 seconds	5 seconds
RTD-1	2 cm	25.124°C	49.982°C	84.985°C	79.998°C
RTD-2	6 cm	25.114°C	50.234°C	88.128°C	79.234°C
RTD-3	10 cm	25.234°C	50.241°C	79.982°C	70.412°C

The effluent hydrogen and oxygen were mixed in the cell headspace. (Note that the inverted funnel described in Ref. 1 was not in use during this experiment.) There were 2 ~ 3 cc of free hydrogen at the time, although this is an open cell so only minimal amounts of gas remain in the headspace. Oxygen gas

and hydrogen gas were also mixed in with the electrolyte solution. It is likely that the platinum mesh anode catalyzed the hydrogen and oxygen to recombine rapidly in the electrolyte, triggering the explosion in the headspace, but this cannot explain all of the energy released.

The vessel was old and may have had a scratch on the inner surface. It is possible that the tungsten cathode may have been exposed to the gas in the headspace.

3.3 Elements on electrode surface

There were many elements deposited on the electrode surface. The major elements were Ca and S and the total mol was roughly estimated at 10^{-6} , as shown in Fig. 11.

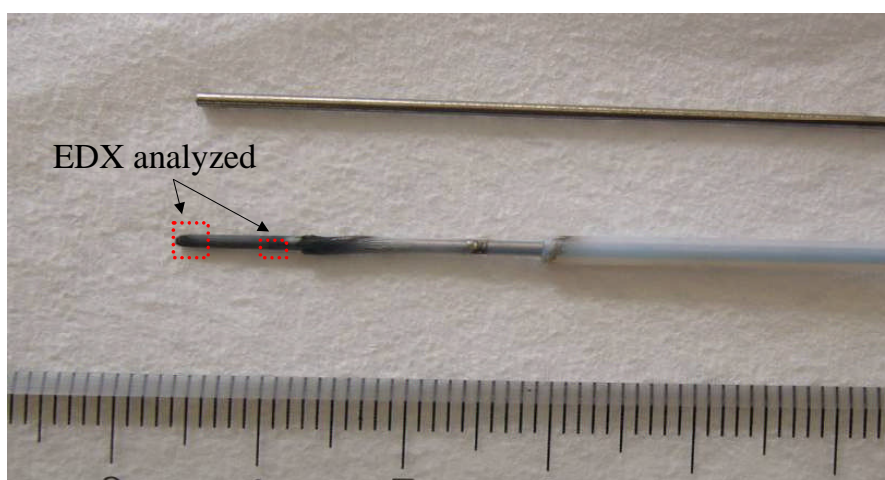

Fig. 9. Electrode. Top: before electrolysis, bottom: after electrolysis.

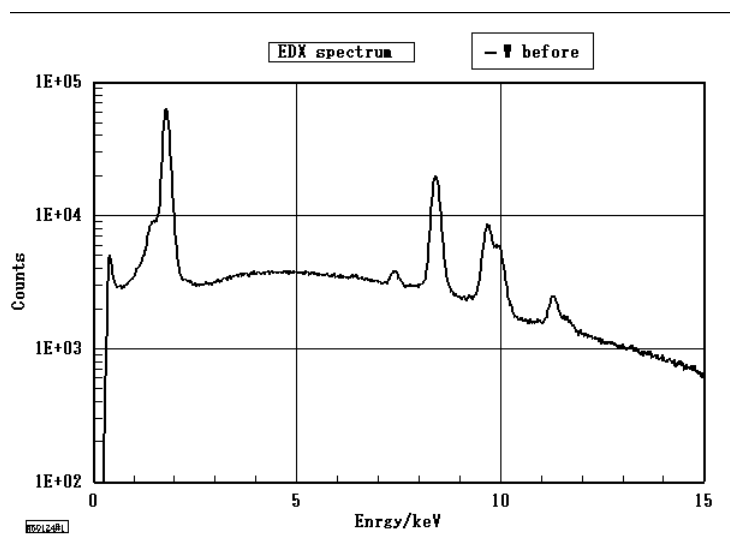

Fig. 10. EDX spectra for W before experiment.

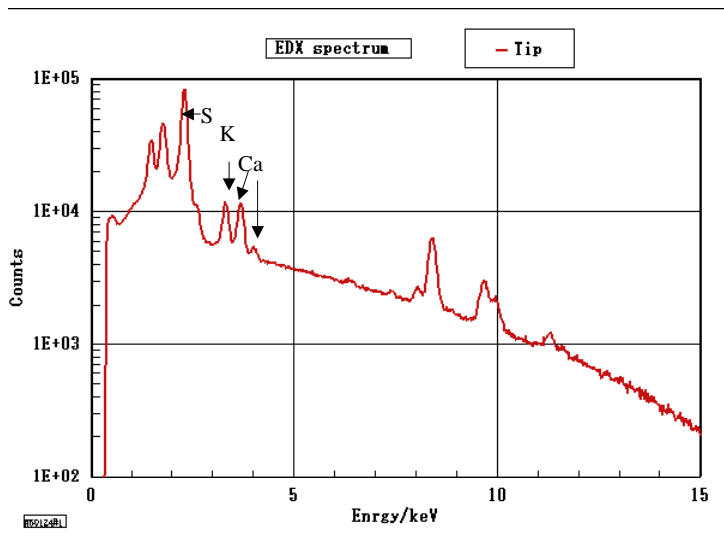

Fig. 11. EDX spectra for W after experiment.

References

1. Tadahiko Mizuno, Tadayoshi Ohmori, Tadashi Akimoto and Akito Takahashi; "Production of Heat during Plasma Electrolysis in Liquid", *Jpn. J. Appl. Phys.* Vol. 39 (2000) pp.6055-6061.
2. Tadahiko Mizuno, Tadashi Akimoto, Kazuhisa Azumi, Tadayoshi Ohmori, Yoshiaki Aoki and Akito Takahashi, "Hydrogen Evolution by Plasma Electrolysis in Aqueous Solution"; *Jpn. J. Appl. Phys.* Vol. 44, No. 1A, 2005, pp.396-401.

Anomalous Energy Generation during Conventional Electrolysis

Mizuno Tadahiko, Yu Toriyabe and
Tadashi Akimoto; *Hokkaido University*

Contents

- An explosive energy release during conventional electrolysis.
- The input voltage and current; 15V and 1.5A, 22.5W.
- Supplied input power ; 10s, less than 300J.
- Heat out; 800 times higher than the input power.
- Many elements deposited on the electrode surface.
- The major element; Ca and S (10^{-6} mol).

Experimental

- Cell: 1000 cc Pyrex glass vessel used for 5 years
- Electrolyte: 700 cc of 0.2M K_2CO_3
- Anode: Pt mesh
- Cathode: W (99.9%) wire 1.5 mm in diameter, 29 cm length, with 3 cm was exposed in the electrolyte.
- Temperature: 20 deg C.

Events

- The event occurred in the first stage of the experiment before plasma normally forms.
- Soon after ordinary electrolysis began, voltage was increased to 15 V and current rose up to 1.5 A.
- Within 10s later, the cell temperature steeply rose up to 80 degree and a bright white flash was surrounded around the cathode.
- The light expanded to the solution and at the same instant the cell exploded.

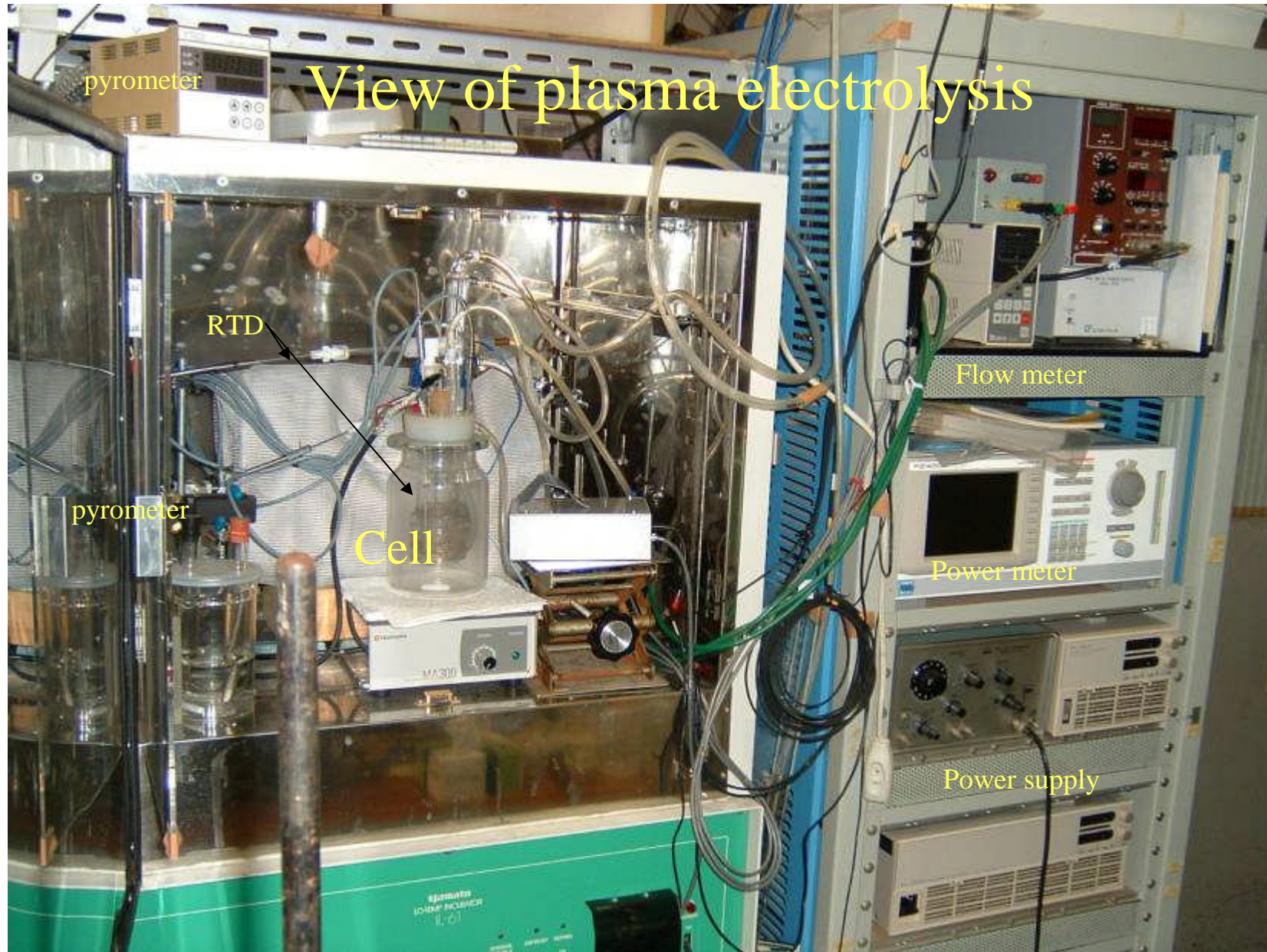

View of plasma electrolysis

pyrometer

RTD

pyrometer

Cell

Flow meter

Power meter

Power supply

Before



Stage 1



Stage 2



Stage 3



Stage 4

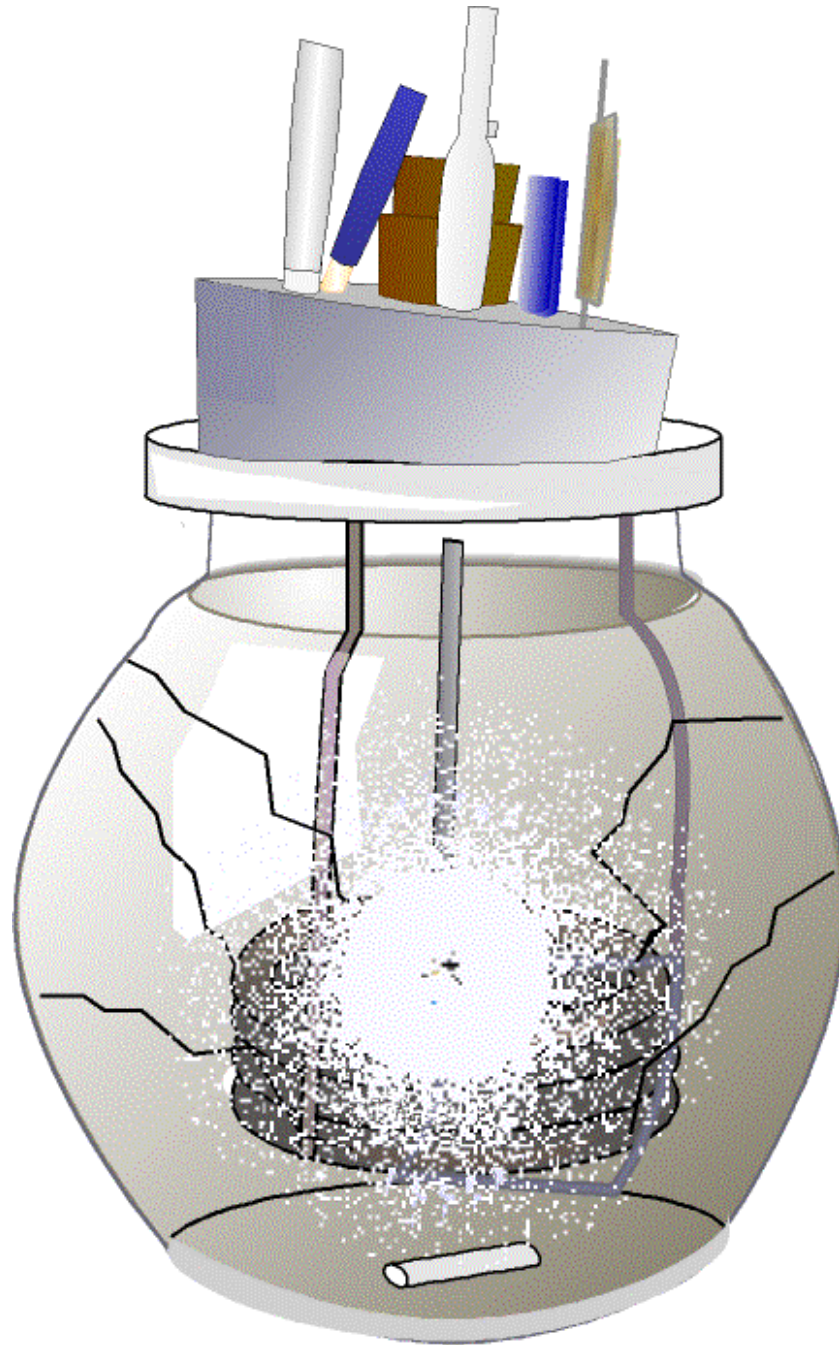

Stage 5



Photo after explosion



Photo after explosion

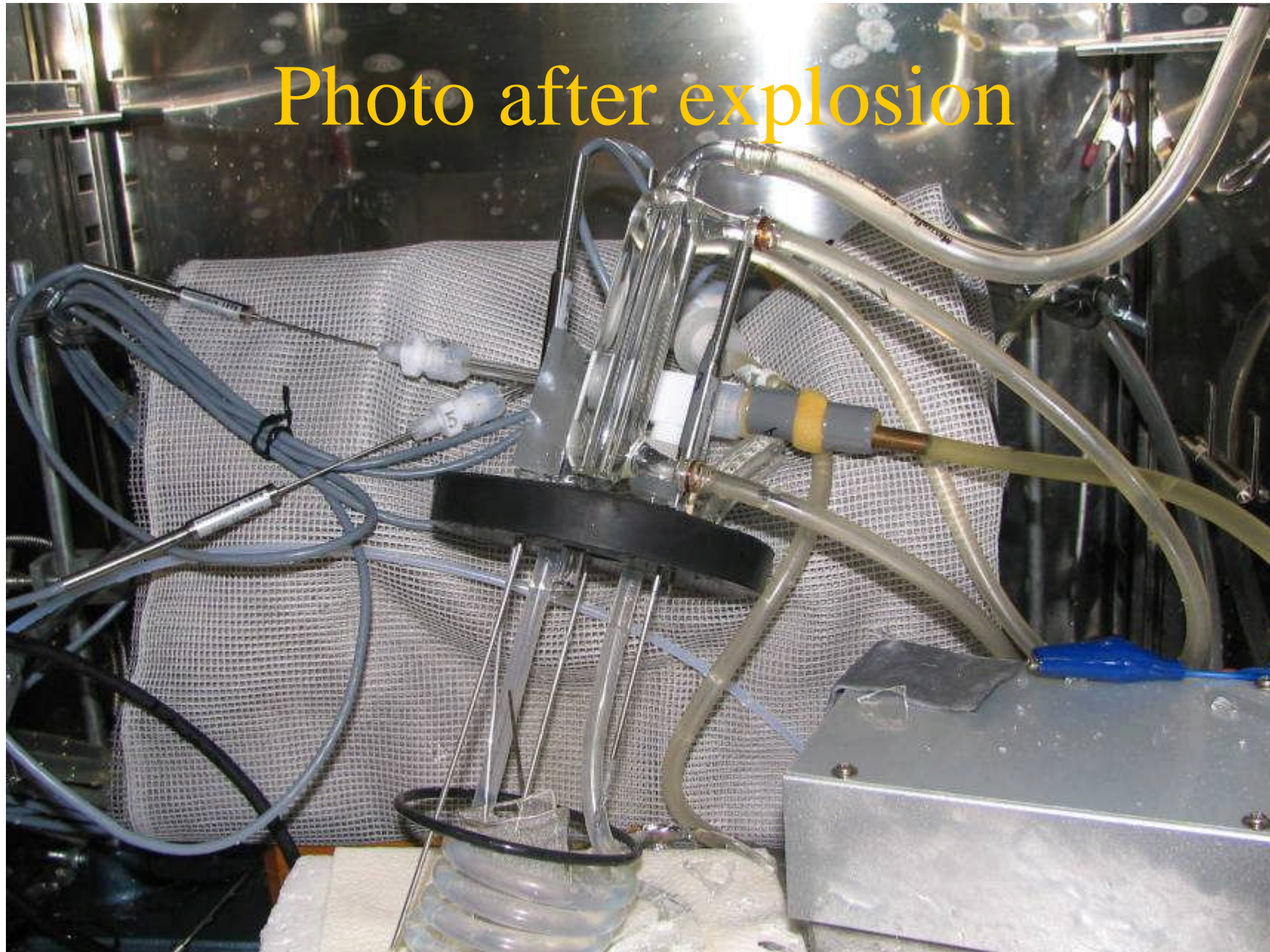
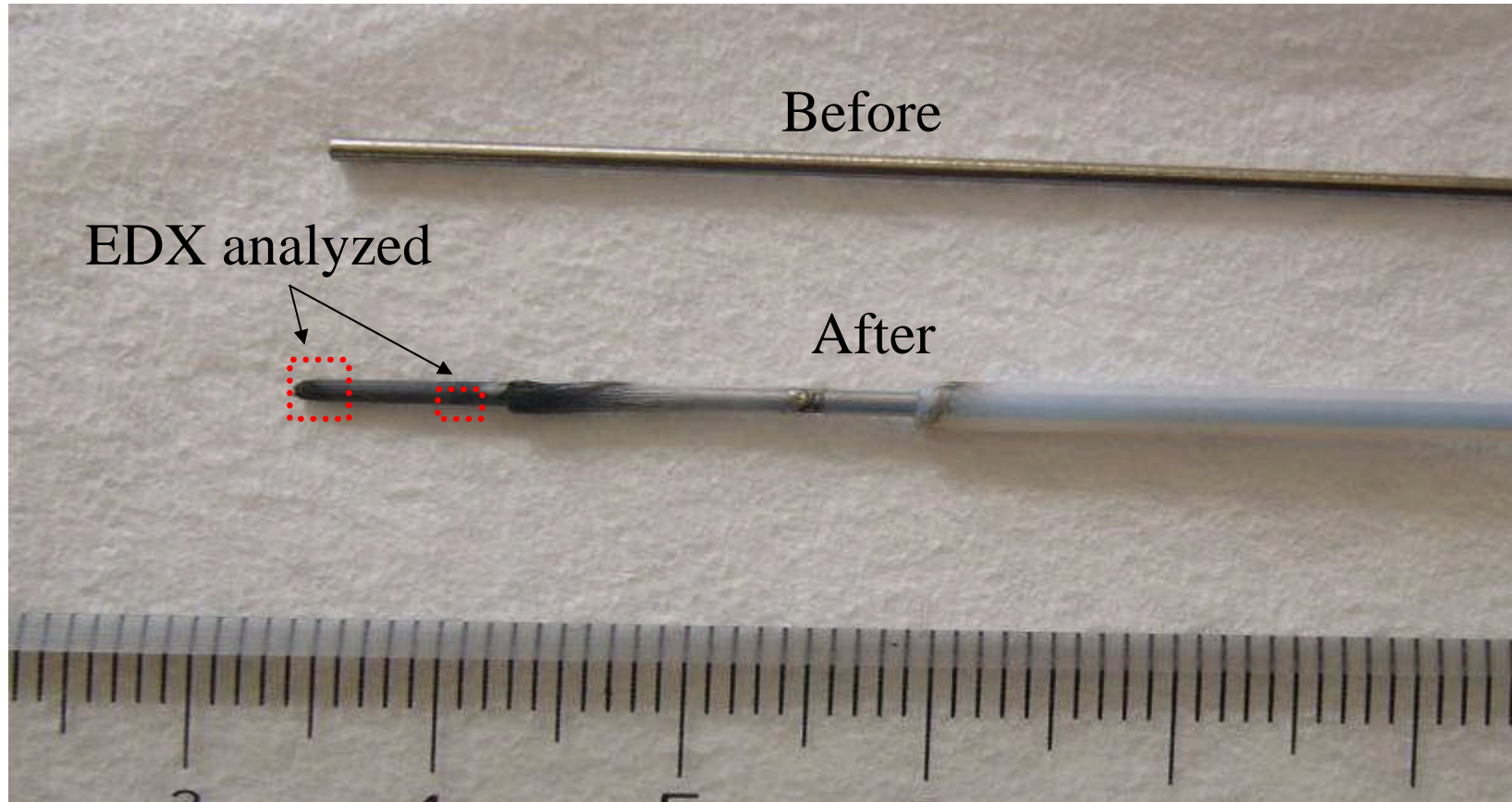
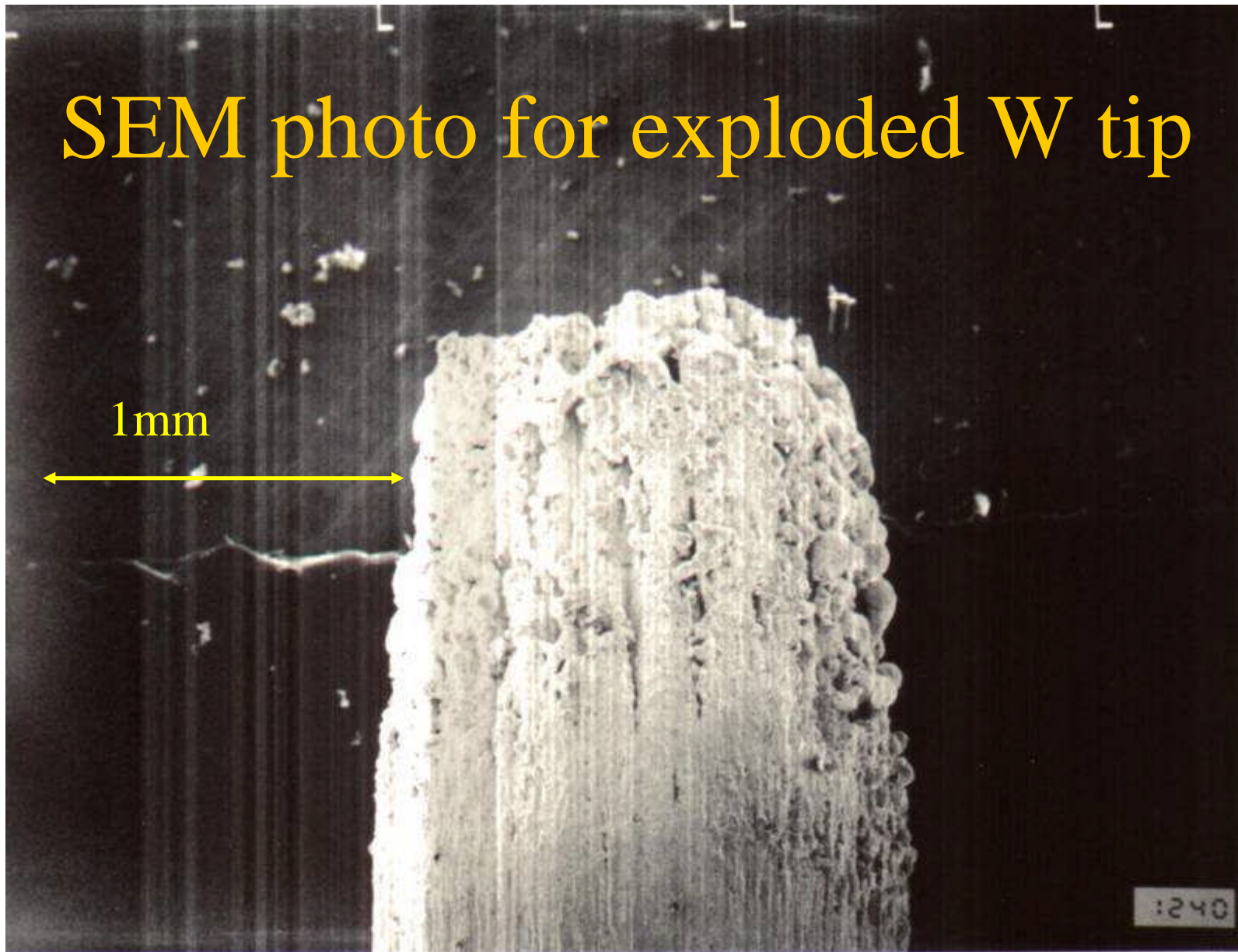

Photo of electrodes



SEM photo for exploded W tip



SEM photo for exploded W side

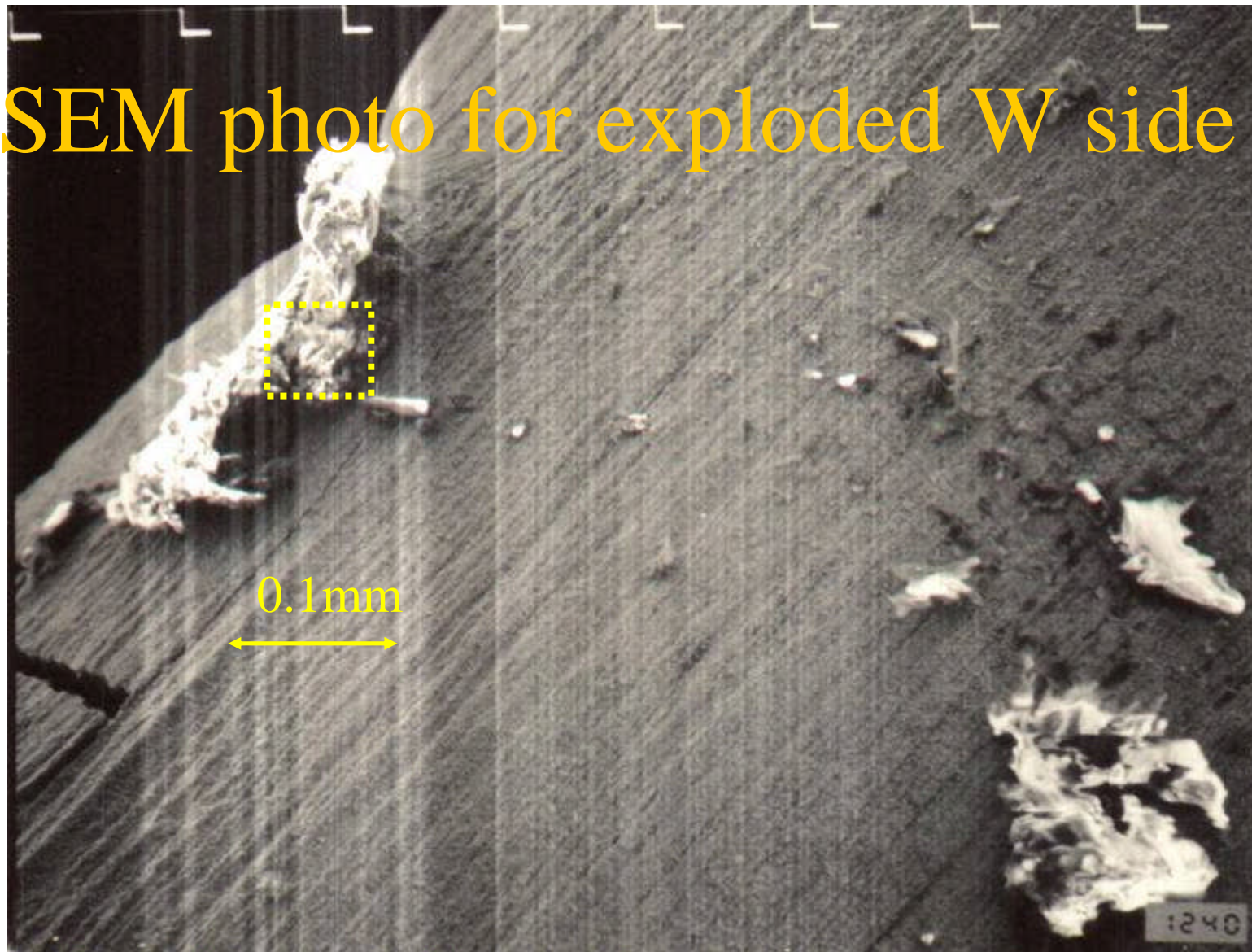

SEM image for exploded W deposition

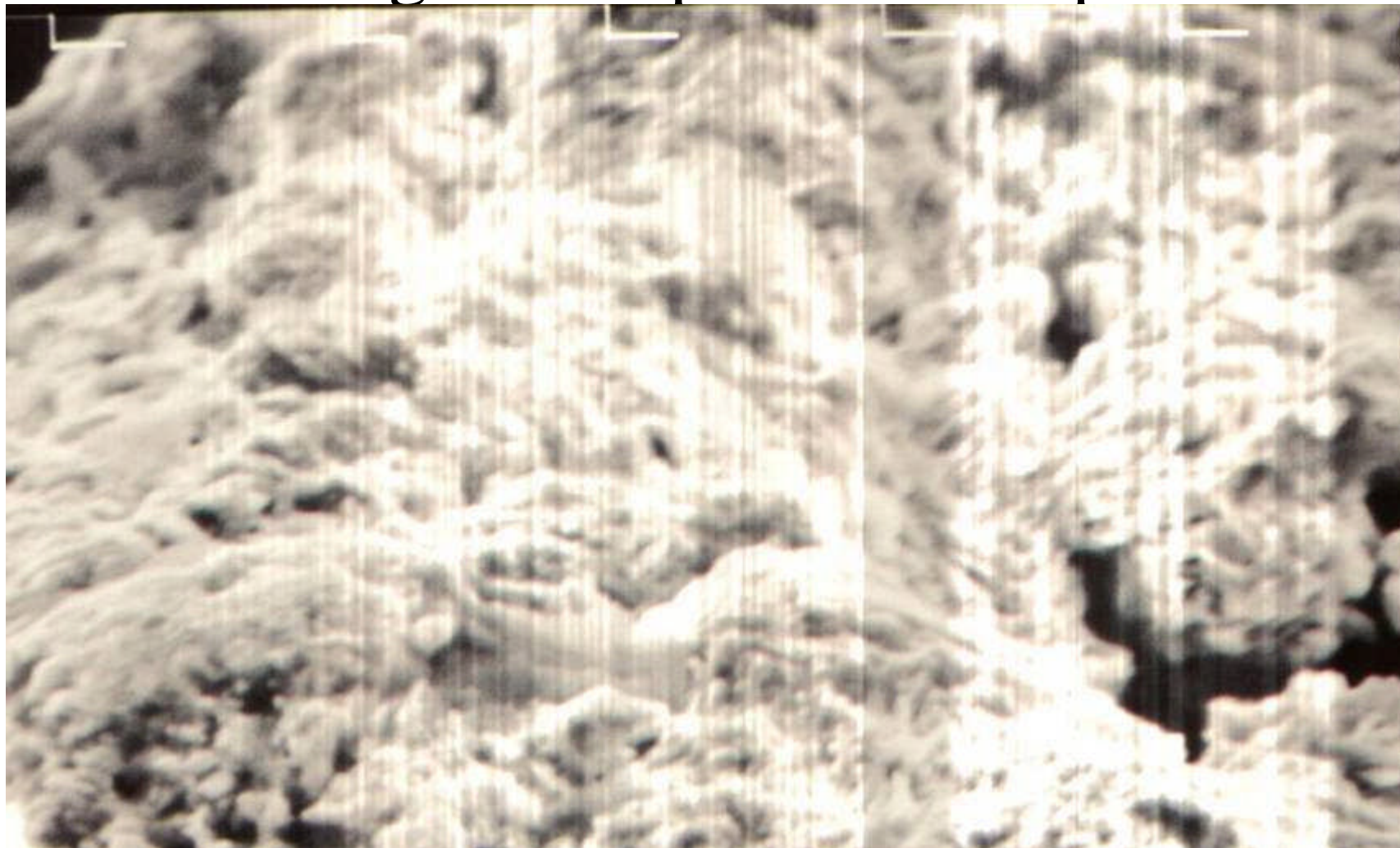

Parameter changes for normal data

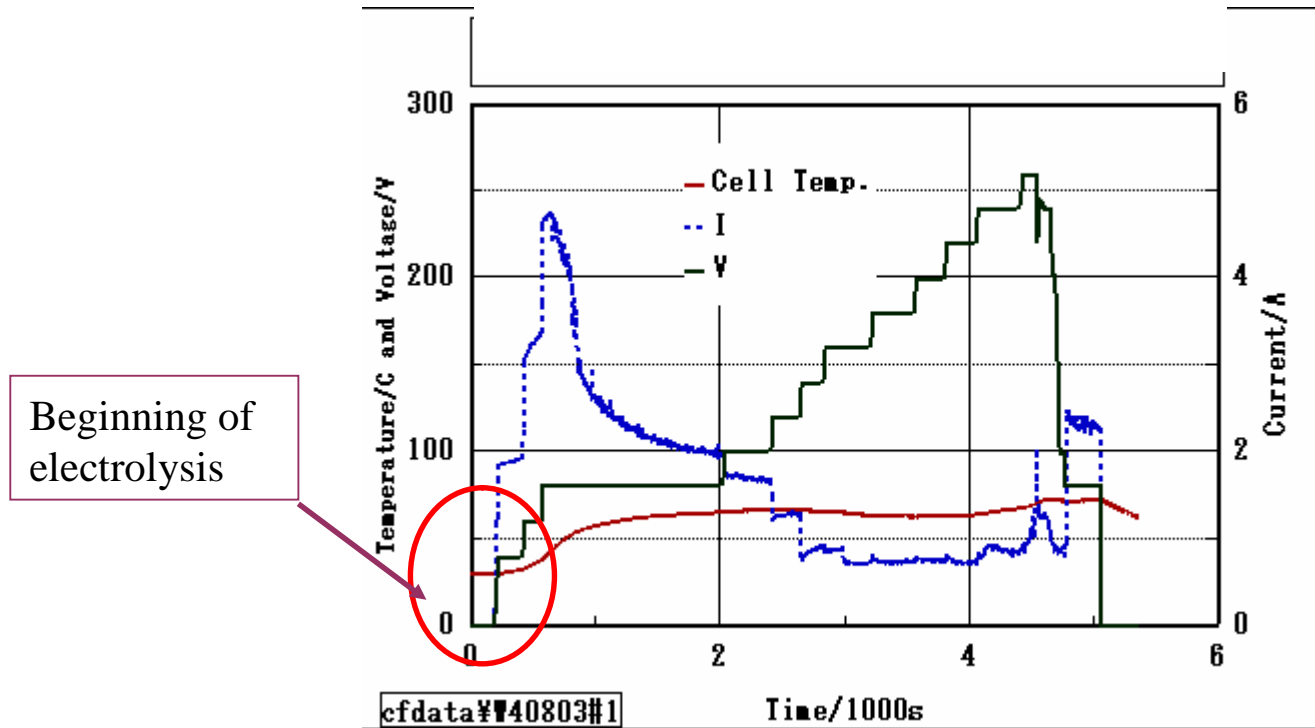

Parameter change for normal data

Voltage
20V

Temperature
2~30°C

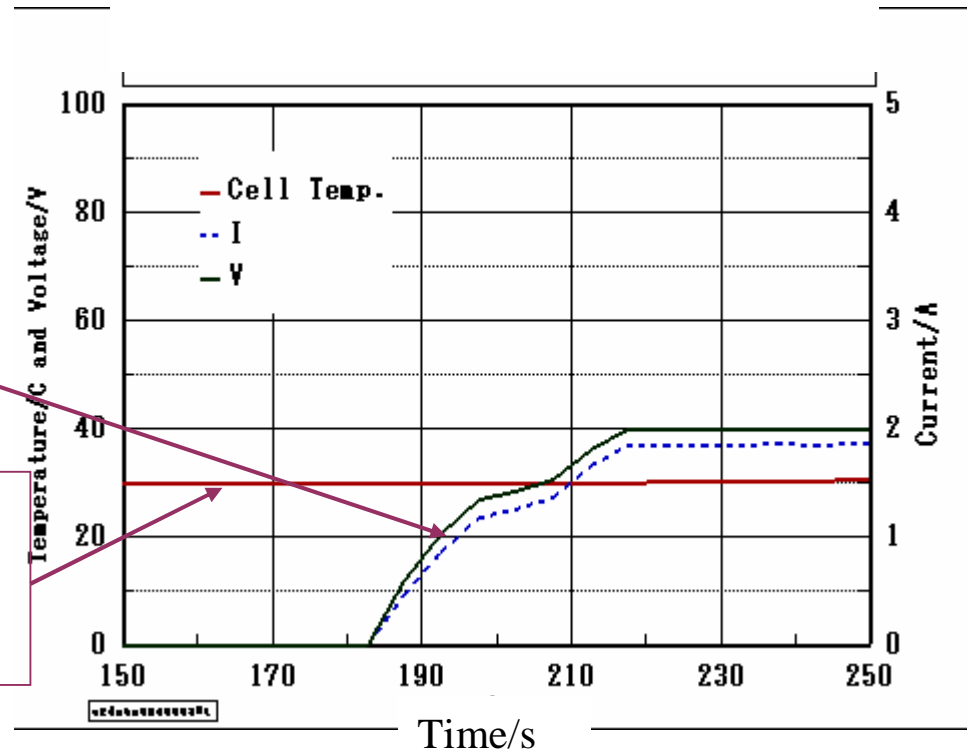

Current efficiency and heat balance for normal data

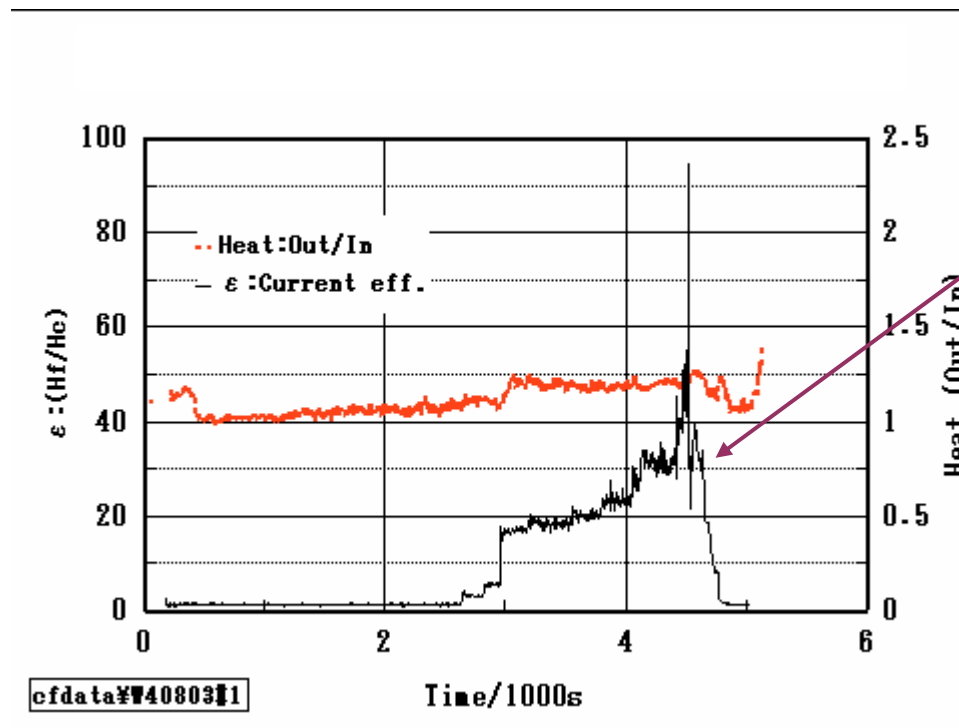

H2 amount
exceed the
Faradic low

Parameter changes for abnormal data

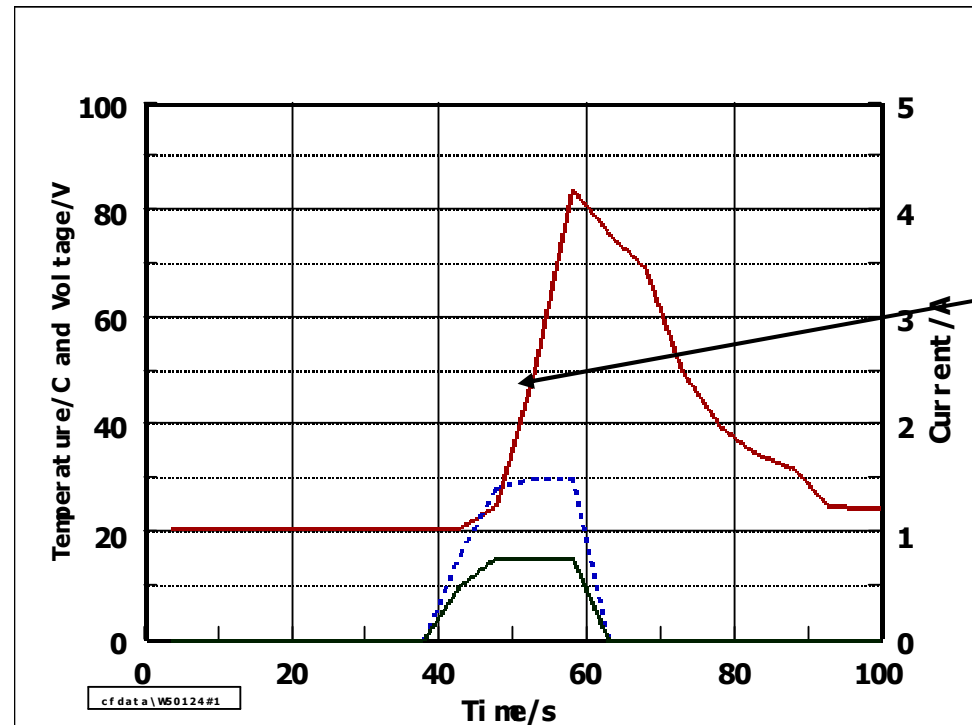

Sudden rose up of electrolyte temperature

Current efficiency and heat balance for abnormal data

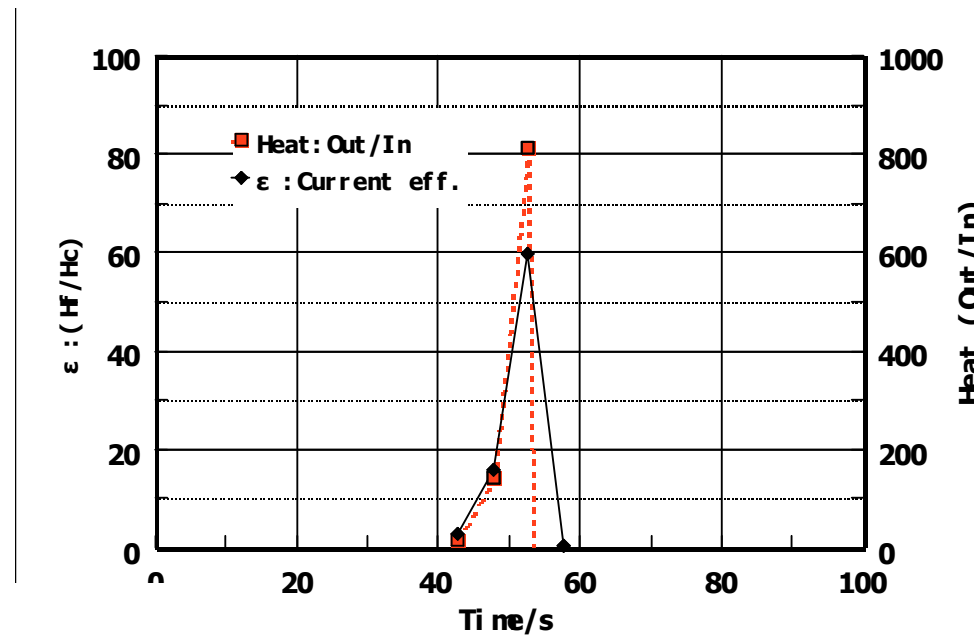

H₂ generation before explosion

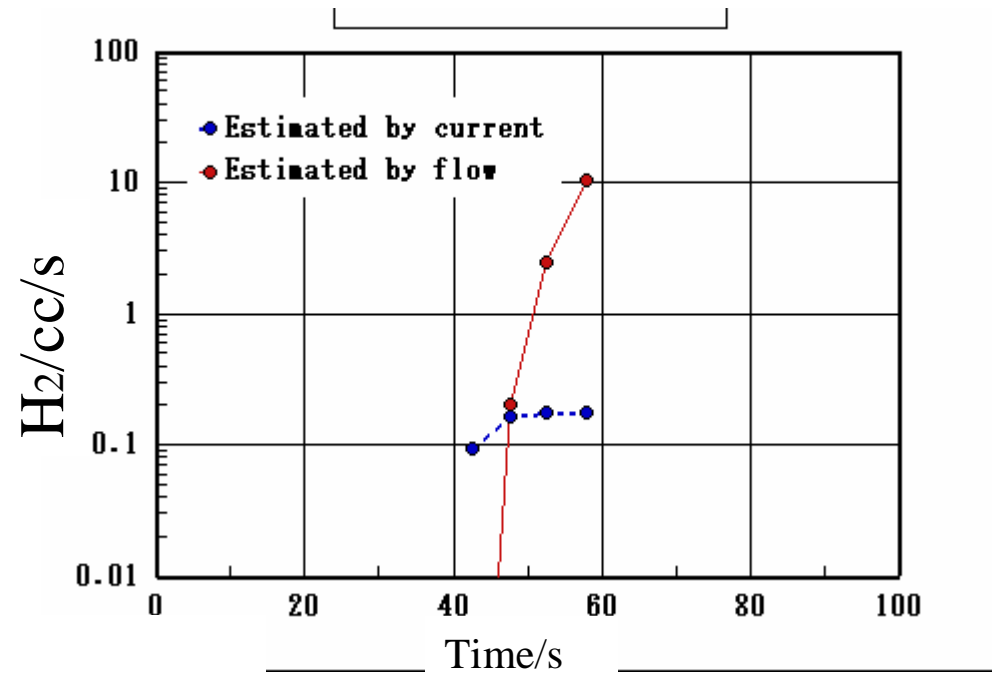

Input and output changes before explosion

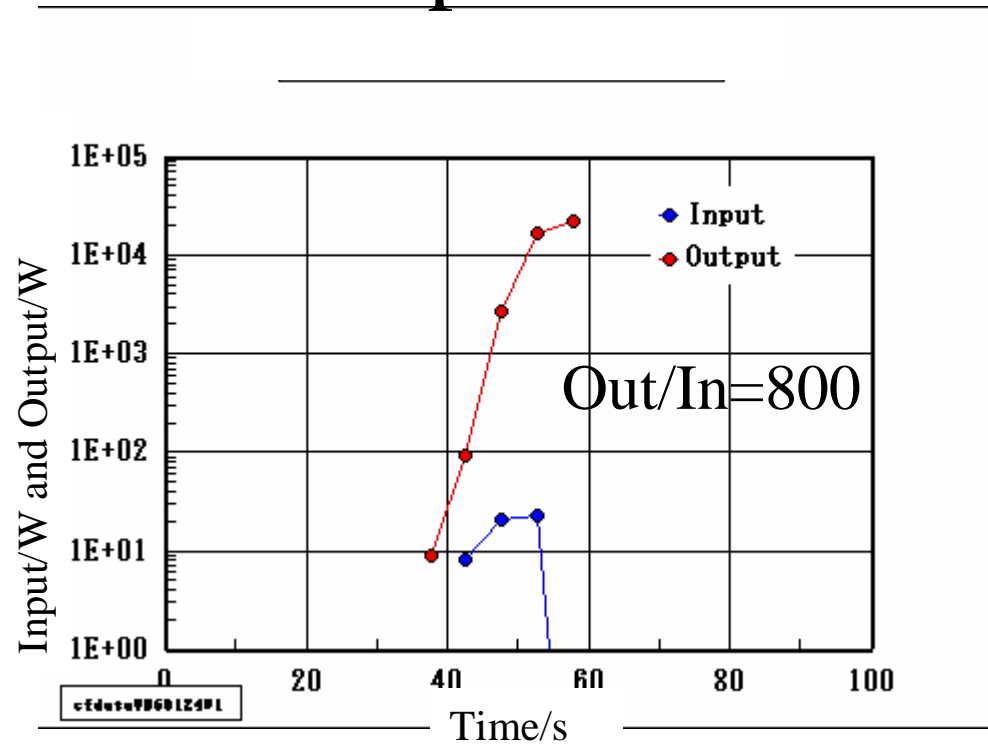

EDX spectrum for normal W

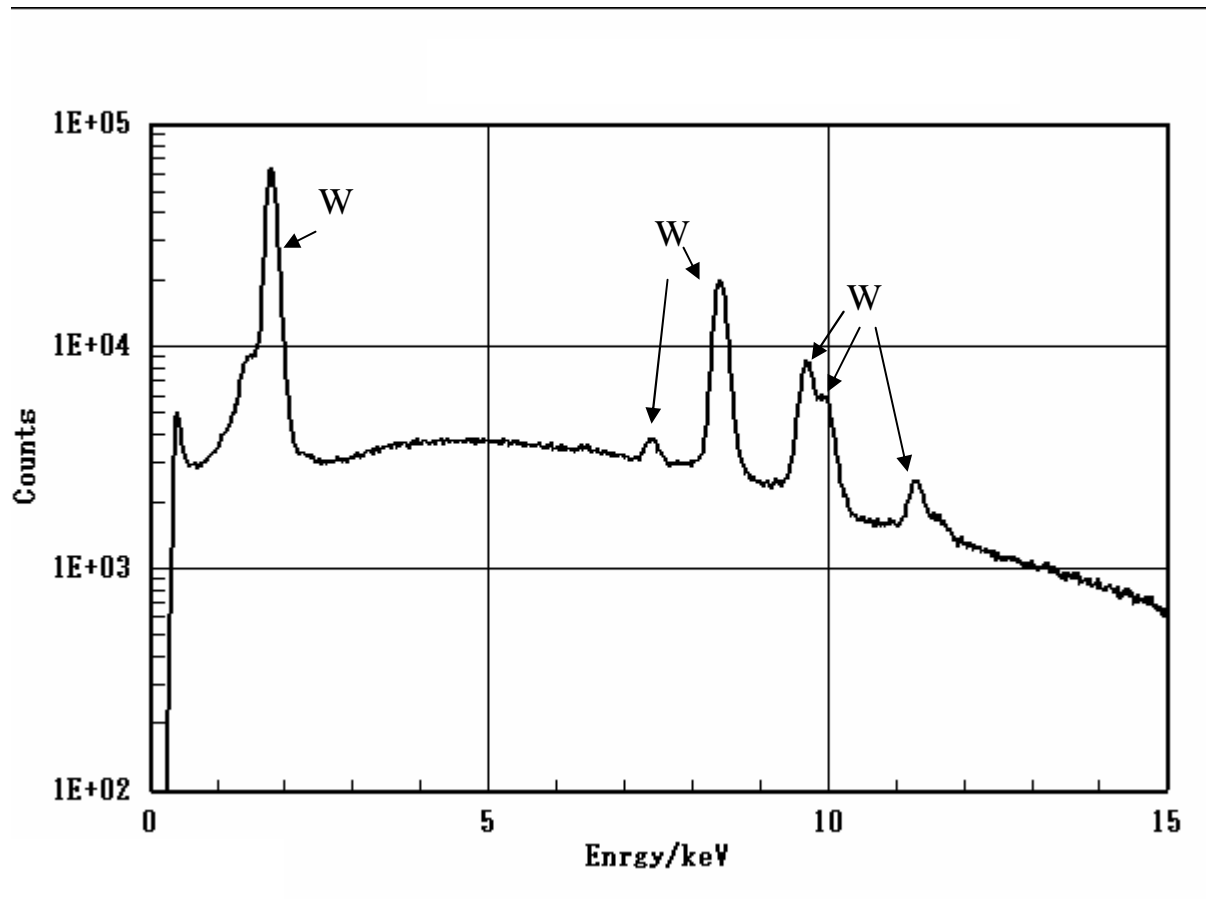

EDX spectrum for exploded W tip

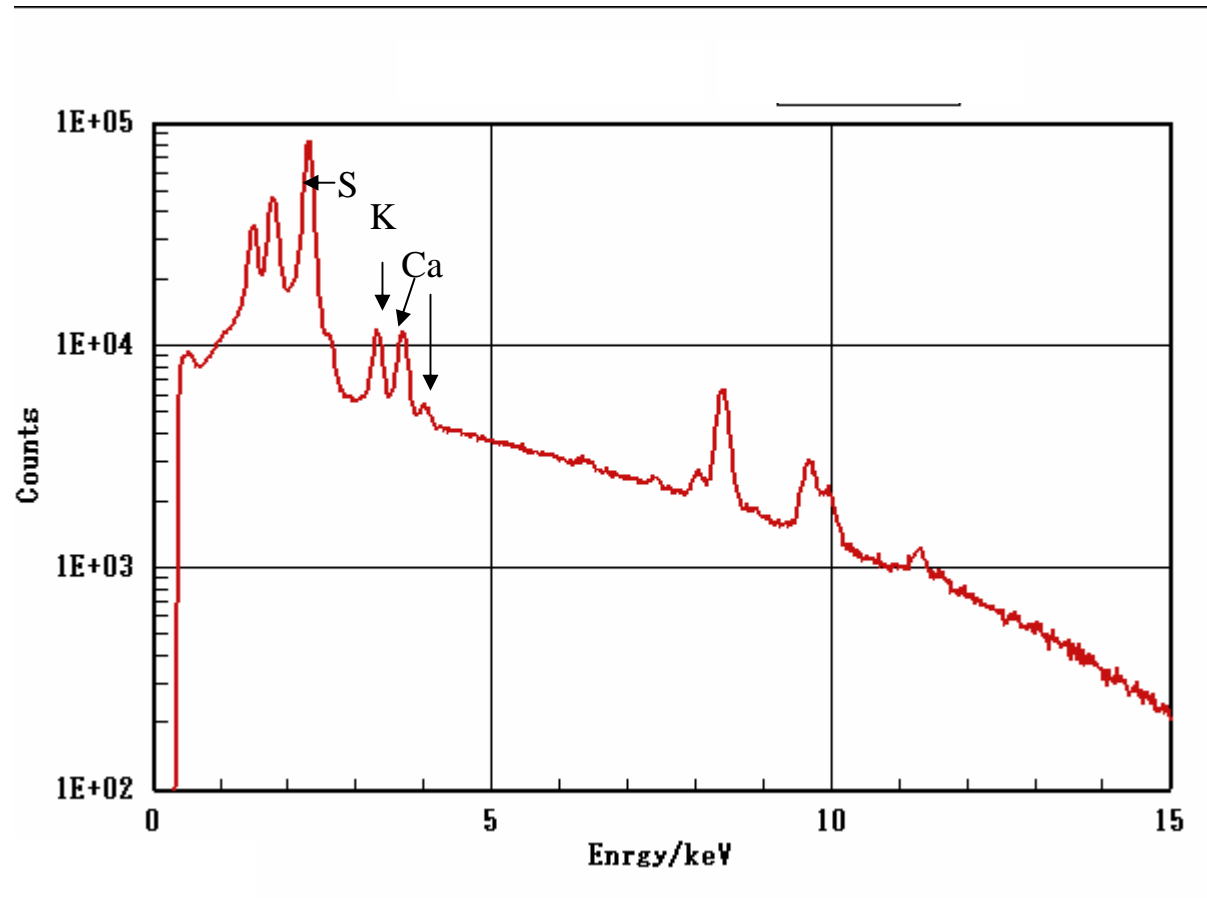

EDX spectrum for exploded W side

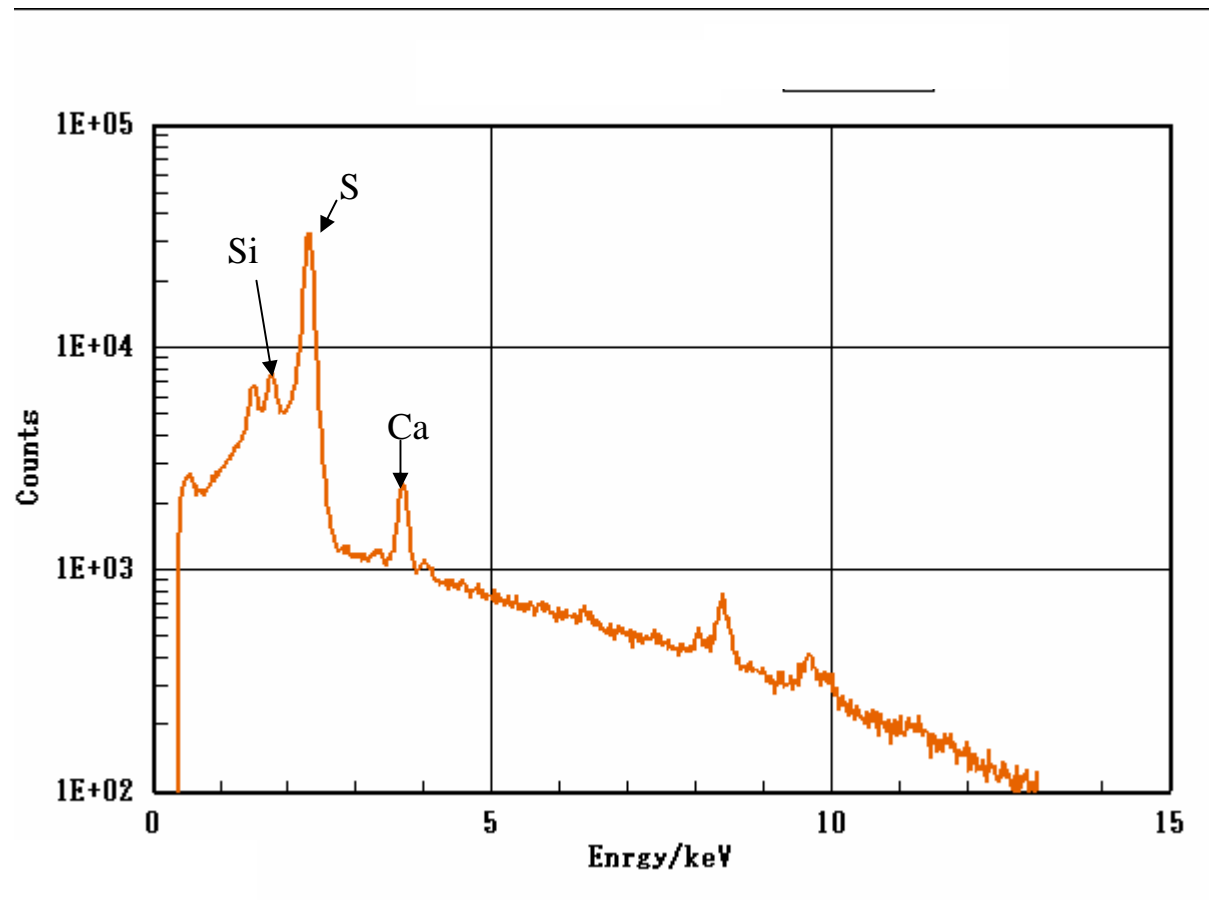

EDX spectrum for exploded W side

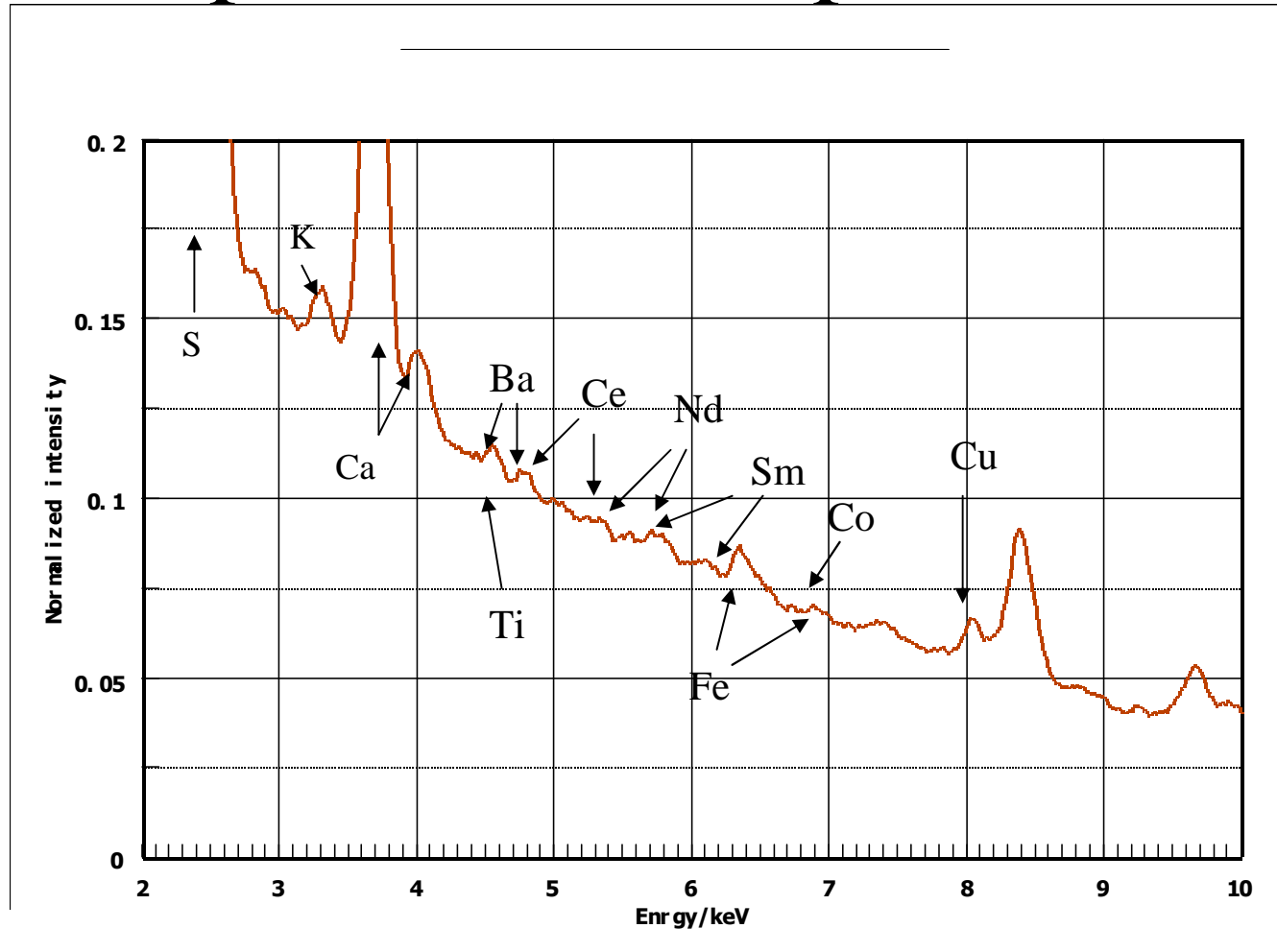

TSC mechanism, ^{182}W (26.3%)

- $^{182}\text{W} + 4^1\text{H} \rightarrow ^{130}\text{Te} + ^{56}\text{Fe} + 128.6\text{MeV}$
- $\rightarrow ^{136}\text{Xe} + ^{50}\text{Cr} + 117.4\text{MeV}$
- $\rightarrow ^{138}\text{Ba} + ^{48}\text{Ti} + 117.4\text{MeV}$
- $\rightarrow ^{142}\text{Ce} + ^{44}\text{Ca} + 107.2\text{MeV}$
- $\rightarrow ^{154}\text{Sm} + ^{32}\text{S} + 79.2\text{MeV}$
- $\rightarrow ^{158}\text{Gd} + ^{28}\text{Si} + 72.7\text{MeV}$

TSC mechanism, ^{184}W (30.6%)

- $^{184}\text{W} + 4^1\text{H} \rightarrow ^{124}\text{Sn} + ^{64}\text{Ni} + 138.9\text{MeV}$
- $\rightarrow ^{130}\text{Te} + ^{58}\text{Fe} + 133.3\text{MeV}$
- $\rightarrow ^{136}\text{Xe} + ^{52}\text{Cr} + 124.9\text{MeV}$
- $\rightarrow ^{138}\text{Ba} + ^{50}\text{Ti} + 123.0\text{MeV}$
- $\rightarrow ^{142}\text{Ce} + ^{46}\text{Ca} + 110.9\text{MeV}$
- $\rightarrow ^{150}\text{Nd} + ^{38}\text{Ar} + 91.3\text{MeV}$
- $\rightarrow ^{154}\text{Sm} + ^{34}\text{S} + 85.7\text{MeV}$
- $\rightarrow ^{160}\text{Gd} + ^{28}\text{Si} + 72.7\text{MeV}$

TSC mechanism, ^{186}W (28.6%)

- $^{186}\text{W} + 4^1\text{H} \rightarrow ^{36}\text{Xe} + ^{54}\text{Cr} + 129.5\text{MeV}$
- $\rightarrow ^{142}\text{Ce} + ^{48}\text{Ca} + 114.6\text{MeV}$
- $\rightarrow ^{150}\text{Nd} + ^{40}\text{Ar} + 95.1\text{MeV}$
- $\rightarrow ^{154}\text{Sm} + ^{36}\text{S} + 89.5\text{MeV}$
- $\rightarrow ^{160}\text{Gd} + ^{30}\text{Si} + 78.3\text{MeV}$

Conclusions

- Heat out was estimated 800 times higher than the input power, based on data recorded before explosion.
- Major detected elements were Si, S, Ca, Ti, Fe, Cr and Cu.
- Minor elements were Ba, Ce, Nd, Gd, Sm and Co.
- TCS mechanism seems to explain these elements production.